

# TOLEDO

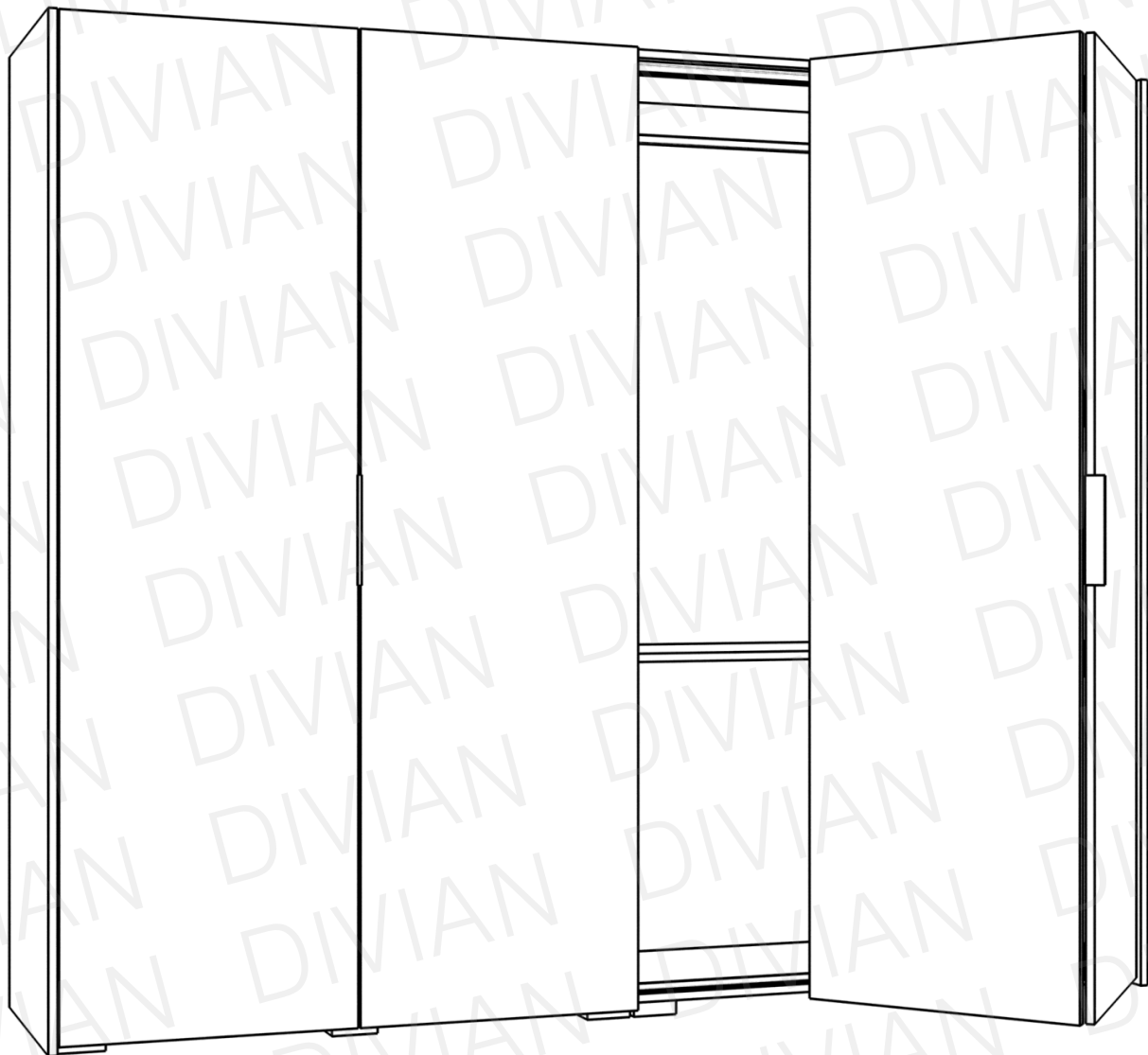

Pontosán kövesse a szerelés lépéseit!

## SZERELÉSI ÚTMUTATÓ

## Gardrób csomag tartalma:

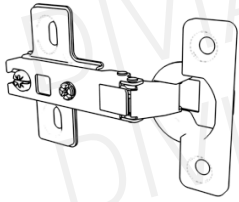

kivetőpánt 8db

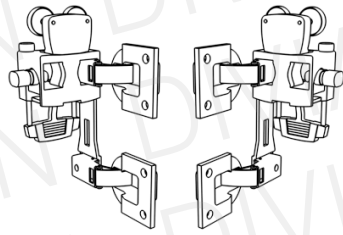

felső görgő 2db  
(jobbos, balos)

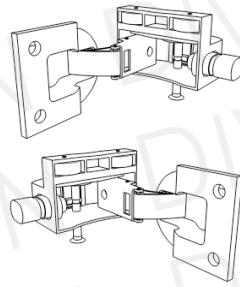

alsó görgő 2db  
(jobbos, balos)

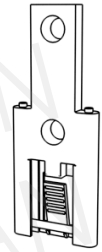

középső pánt  
alsó elem 8db

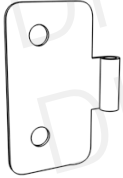

középső pánt  
felső elem 8db



bútorösszehúzó  
hüvely  
M6x30 8db



bútorösszehúzó  
csavar  
M4x12 8db



bútorösszehúzó  
csavar  
M4x25 16db

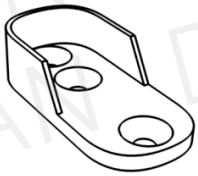

rúdtárcsa 4db



3,5x16 csavar 8db



takarósapka 10db



4x18 csavar 100db

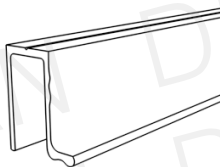

felső sín 1db

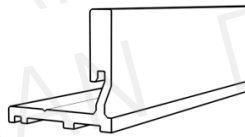

alsó sín 1db



fogó 2db

## Szükséges szerszámok:

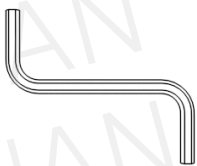

**Ne egyedül végezze  
az összeállítást!**

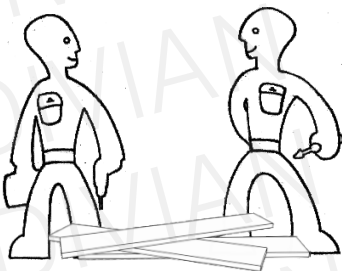

**Óvja az elemeket a sérülésektől!**

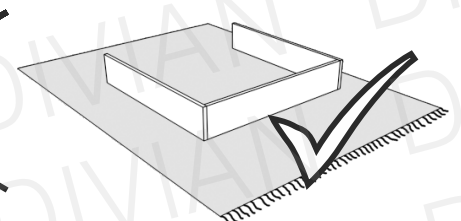
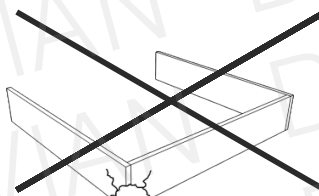

A csomagok több alkatrészt tartalmazhatnak, mint amennyire szüksége van!

# 1

8x M6x30 8x M4x12

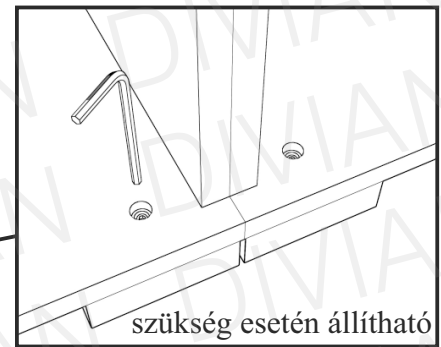
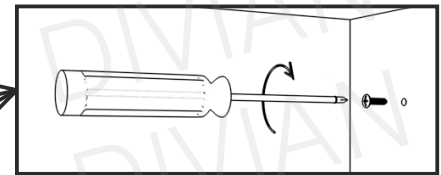
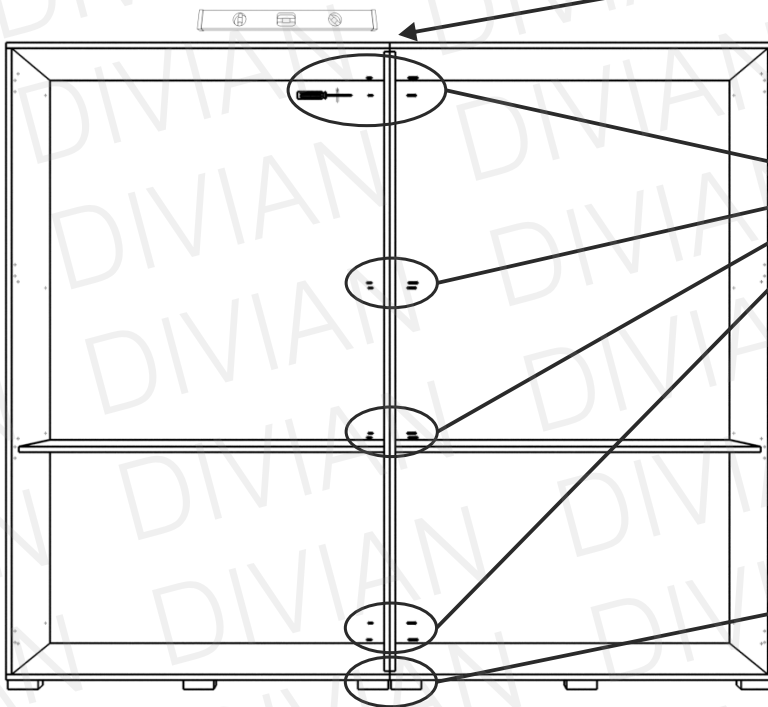
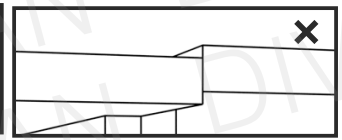
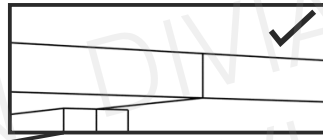
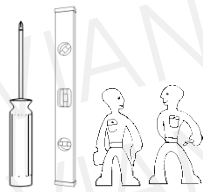

**i** A belső mozdítható elrendezést szedjük ki a korpuzokból (fiókkonténer, polcok, mandlirudak), mielőtt összeillesztik az elemeket!

# 2

16x M4x25

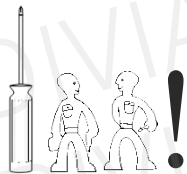

**i** Szereljük fel a 2 oldalfalat a bútorösszehúzó csavarok segítségével.

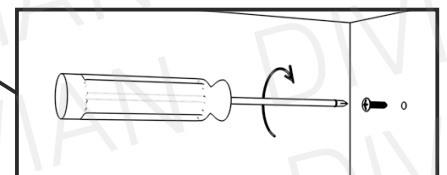
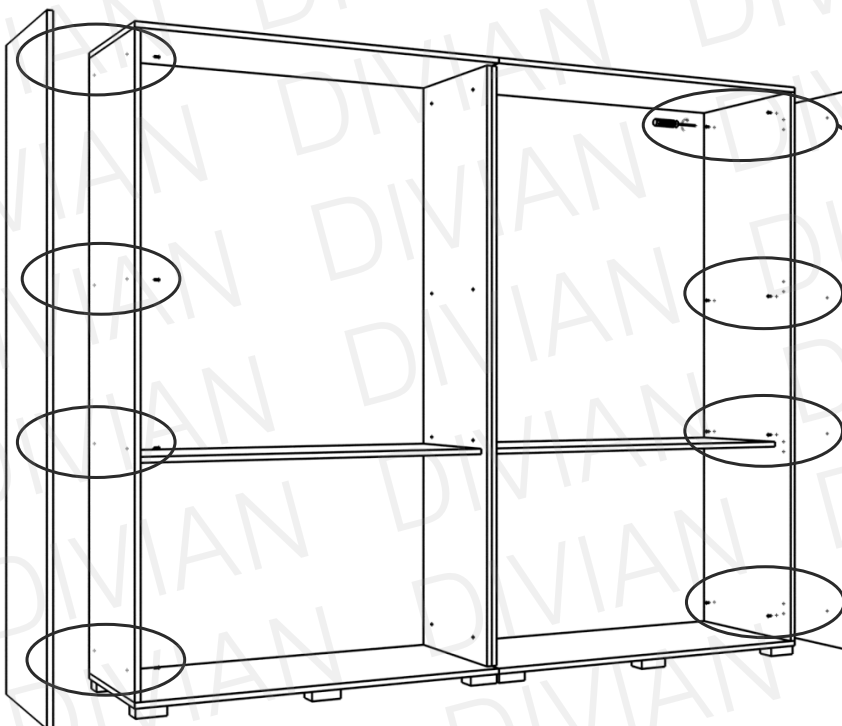

# 3

3

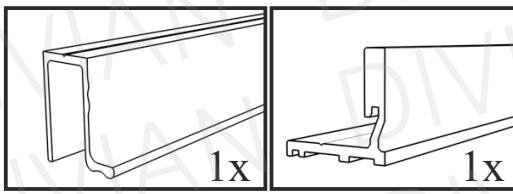

20x

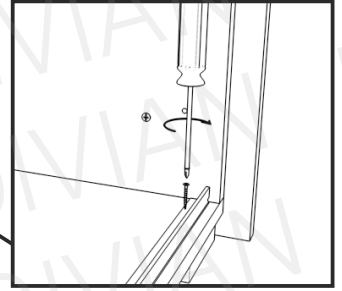
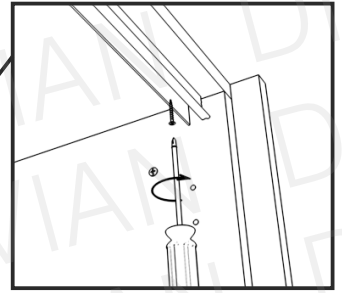
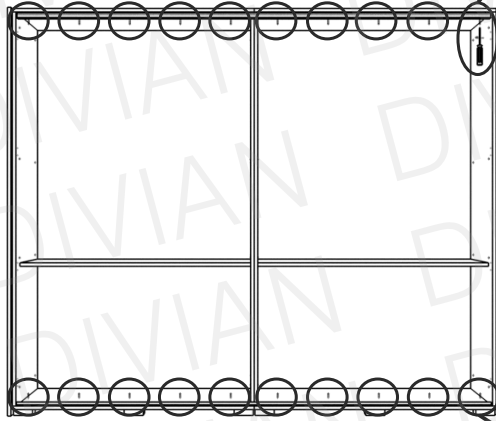
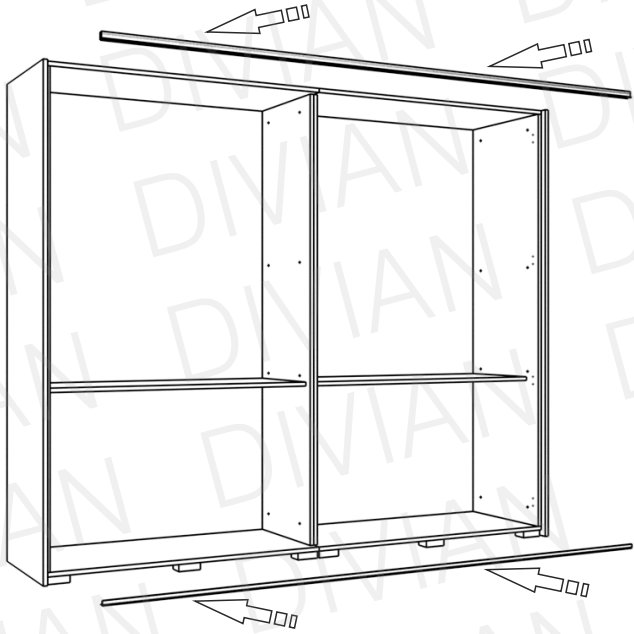
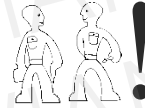

4



Tervezzék el az ajtó panelek helyzetét!

HÁTULNÉZET:

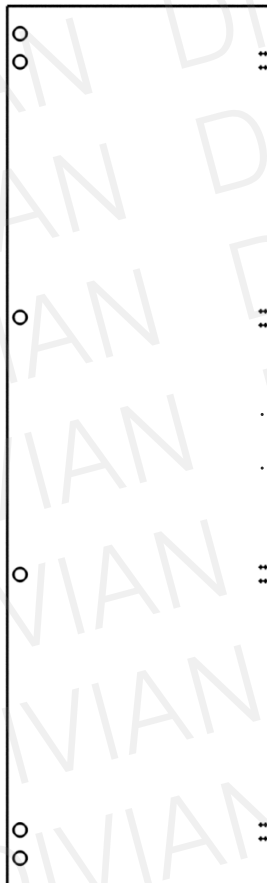

Jobbos ajtó  
külső panel



Jobbos ajtó  
belső panel



Balos ajtó  
belső panel

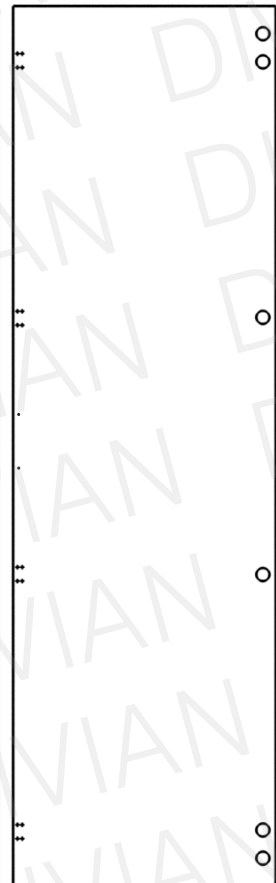

Balos ajtó  
külső panel

# Balos ajtó, külső panel

5

4x

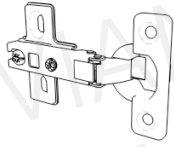

4x



1x



18x



4x18

2x

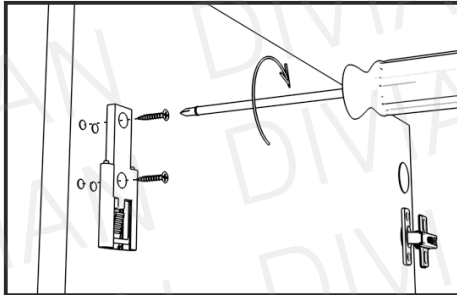

i

A panel széléhez közelebbi, külső 2 furatba csavarja be az alkatrészt!

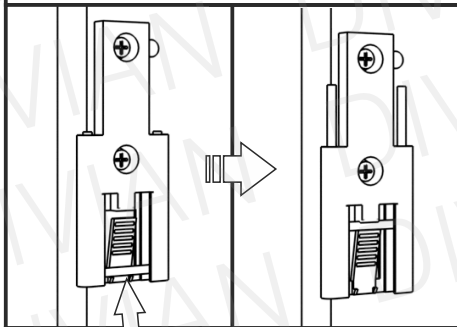

i

Tolja fel az alkatrész U alakú fém részét!

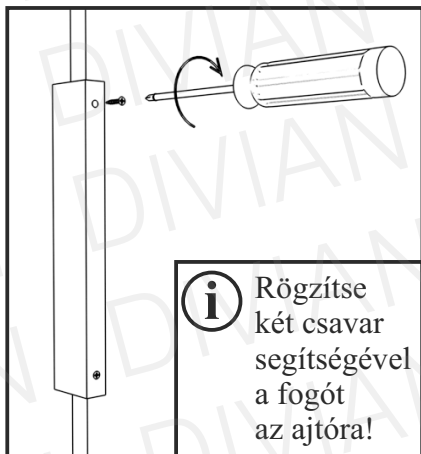

i

Rögzítse két csavar segítségével a fogót az ajtóra!

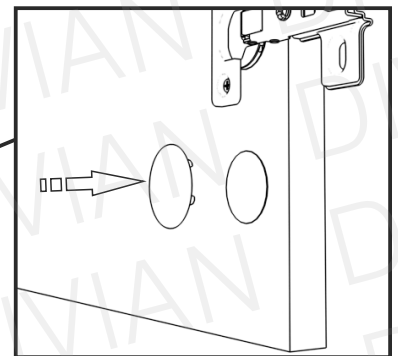
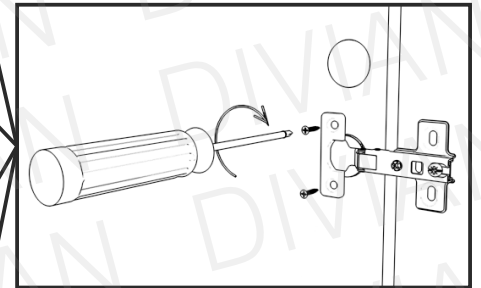
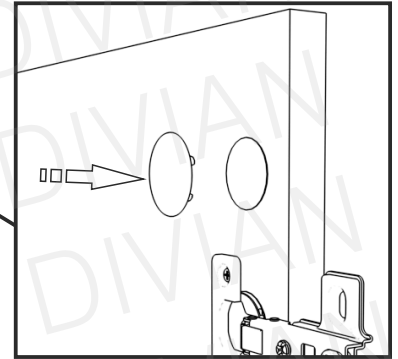

# Balos ajtó, belső panel

6

1x

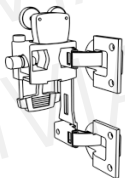

1x

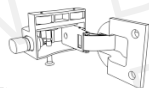

4x



14x



4x18

3x

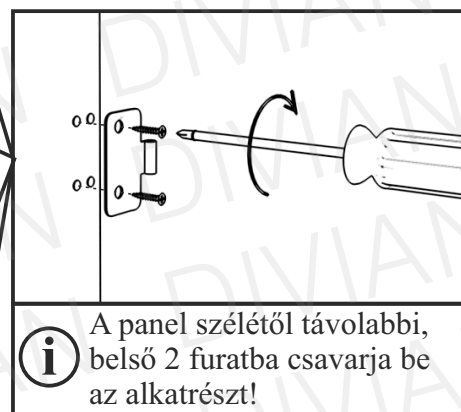
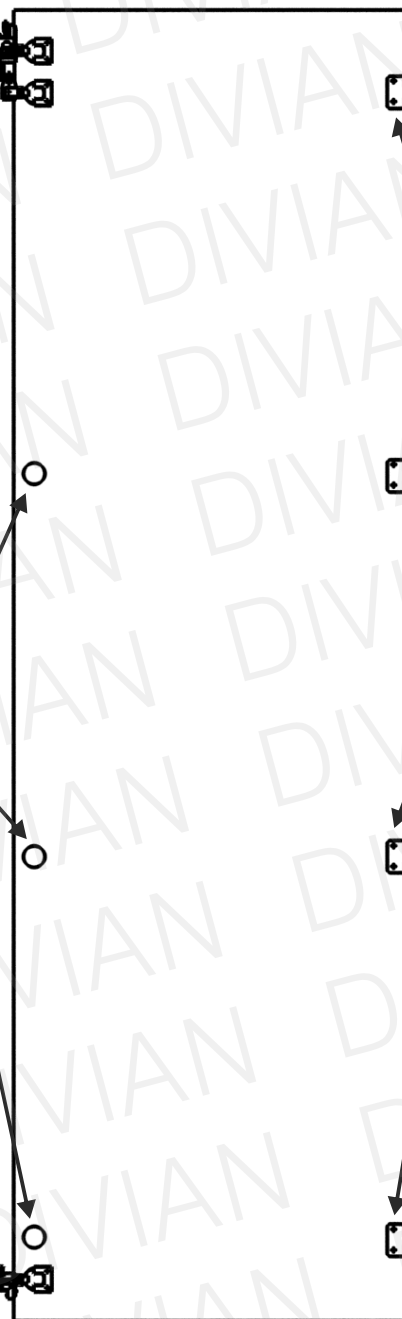
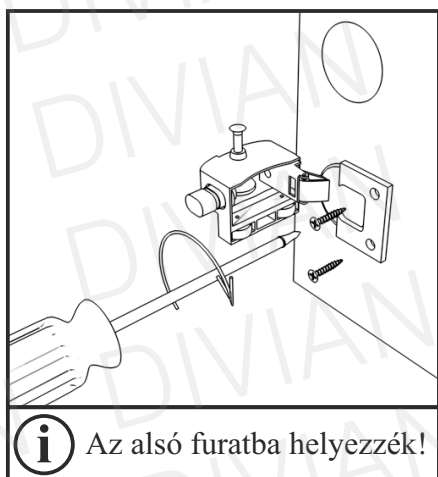
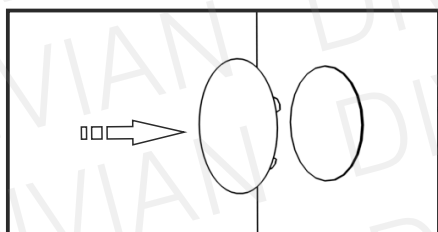
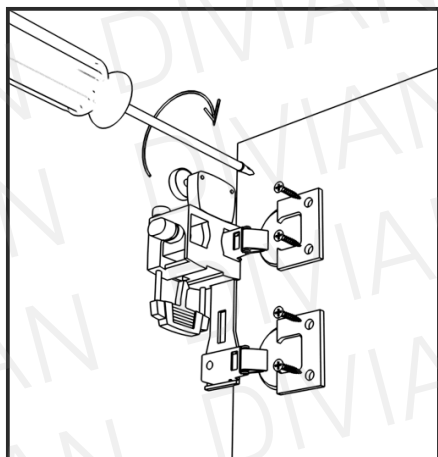

**i** Az alsó furatba helyezték!

# Jobbos ajtó, belső panel

7

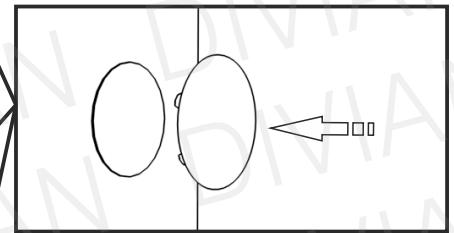
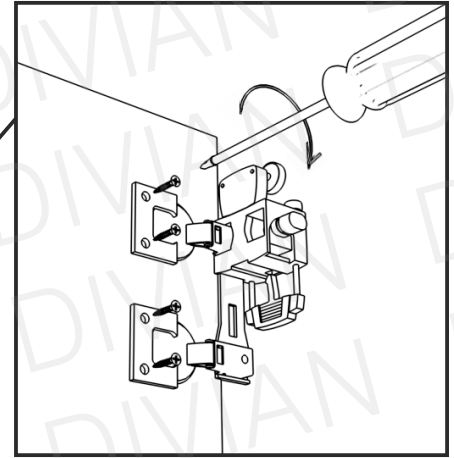
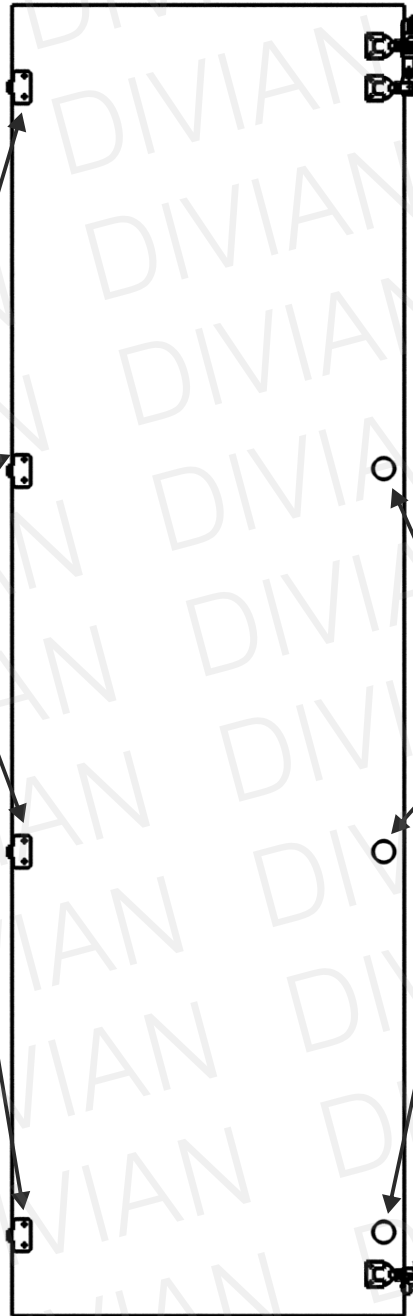
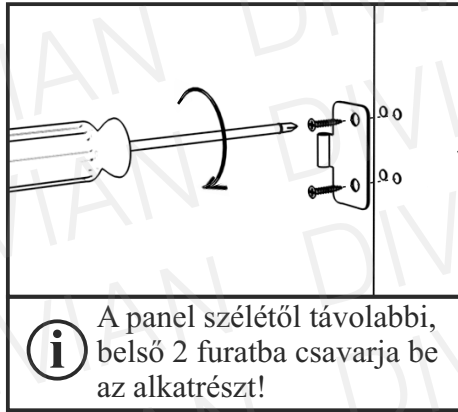
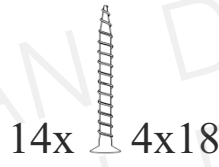
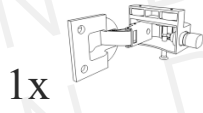
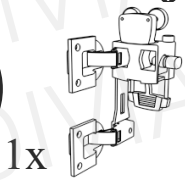

# Jobbos ajtó, külső panel

8

4x

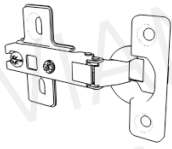

4x



1x



18x



4x18

2x

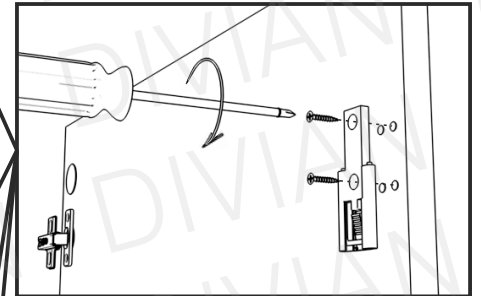
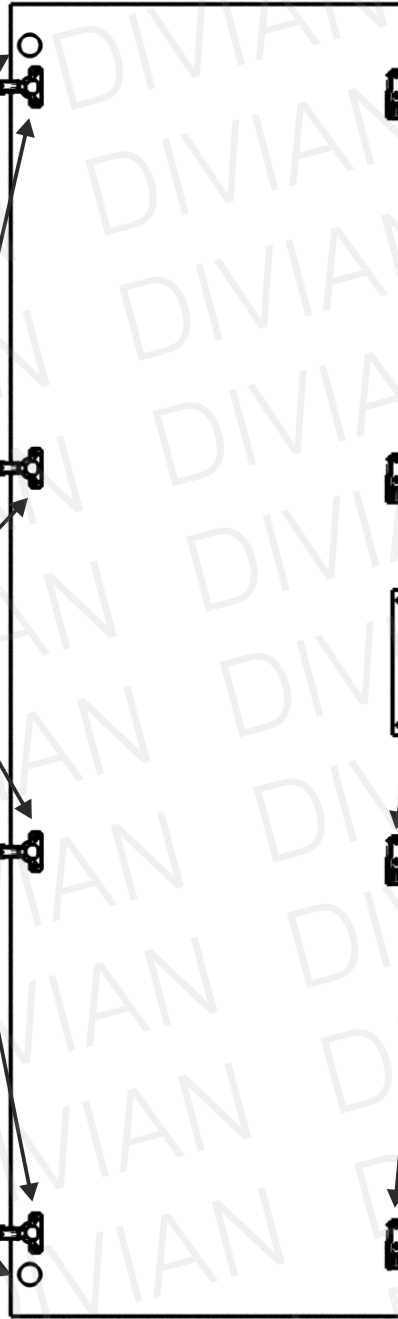
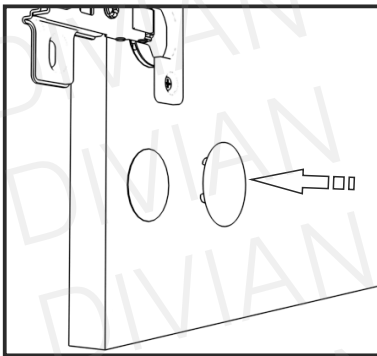
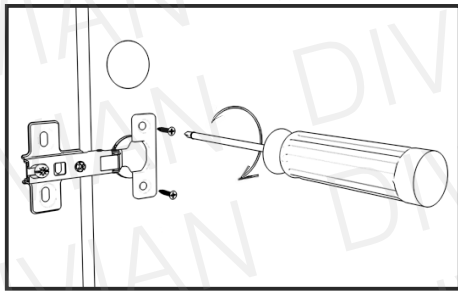
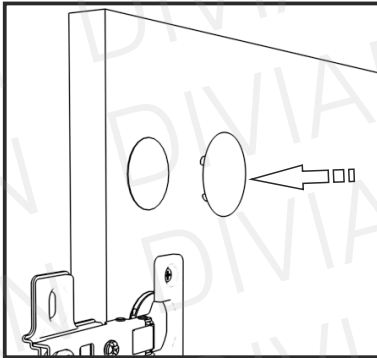

**i** A panel széléhez közelebbi, külső 2 furatba csavarja be az alkatrészt!

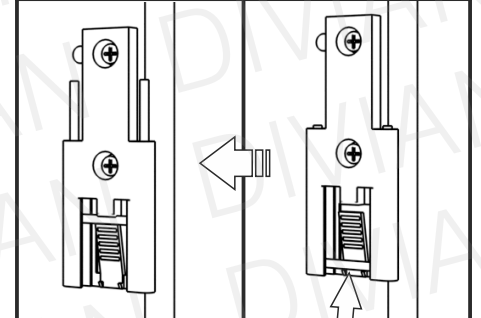

**i** Tolja fel az alkatrész U alakú fém részét!

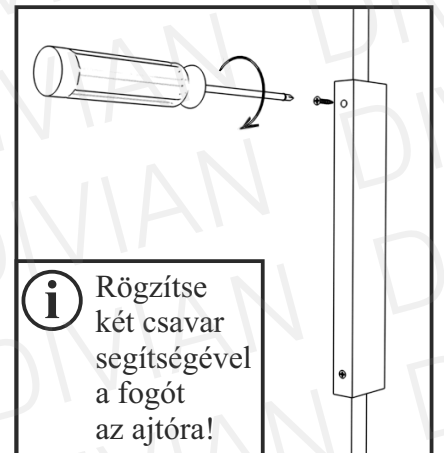

**i** Rögzítse két csavar segítségével a fogót az ajtóra!



9

8x 4x18

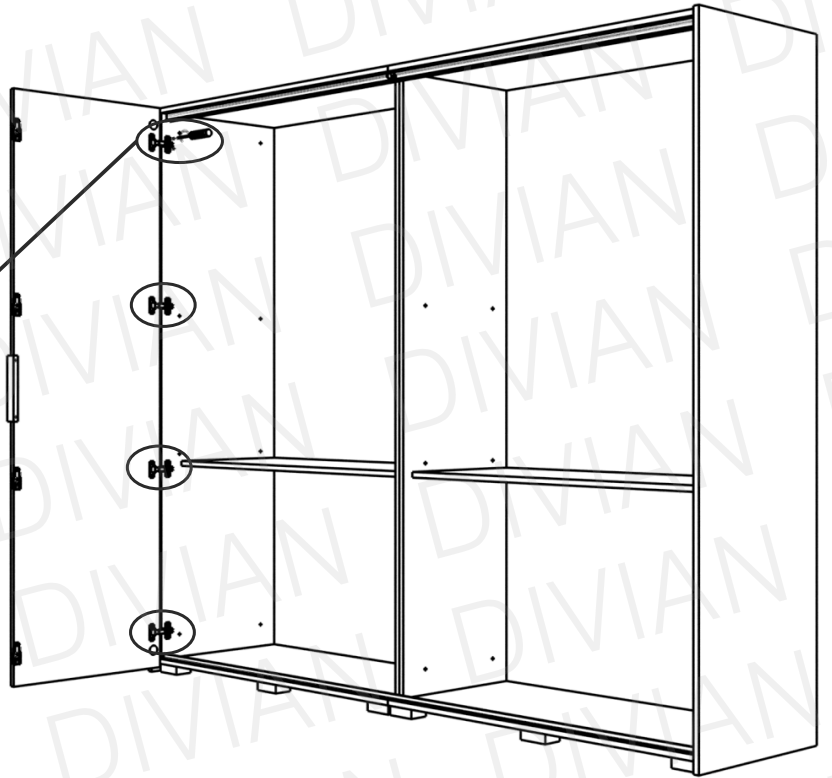
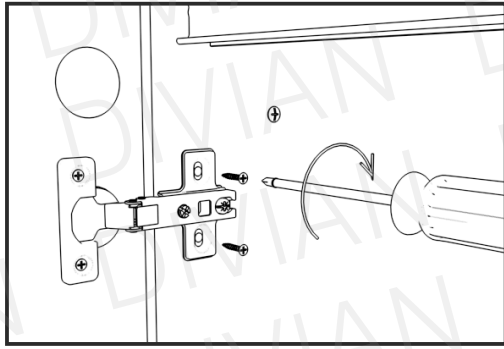
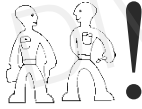

i

Az ajtók rögzítése után, amennyiben szükségesnek látják, a pántokon lévő két csavar segítségével állíthatják be az ajtók pontos helyzetét.

10

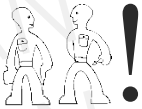

i

A belső ajtó panelt óvatosan illesszék rá a külső ajtó panelre a 4 darab pánt segítségével. A két ajtó panel egymásra merőlegesen álljon, így könnyebben összeilleszthetőek.

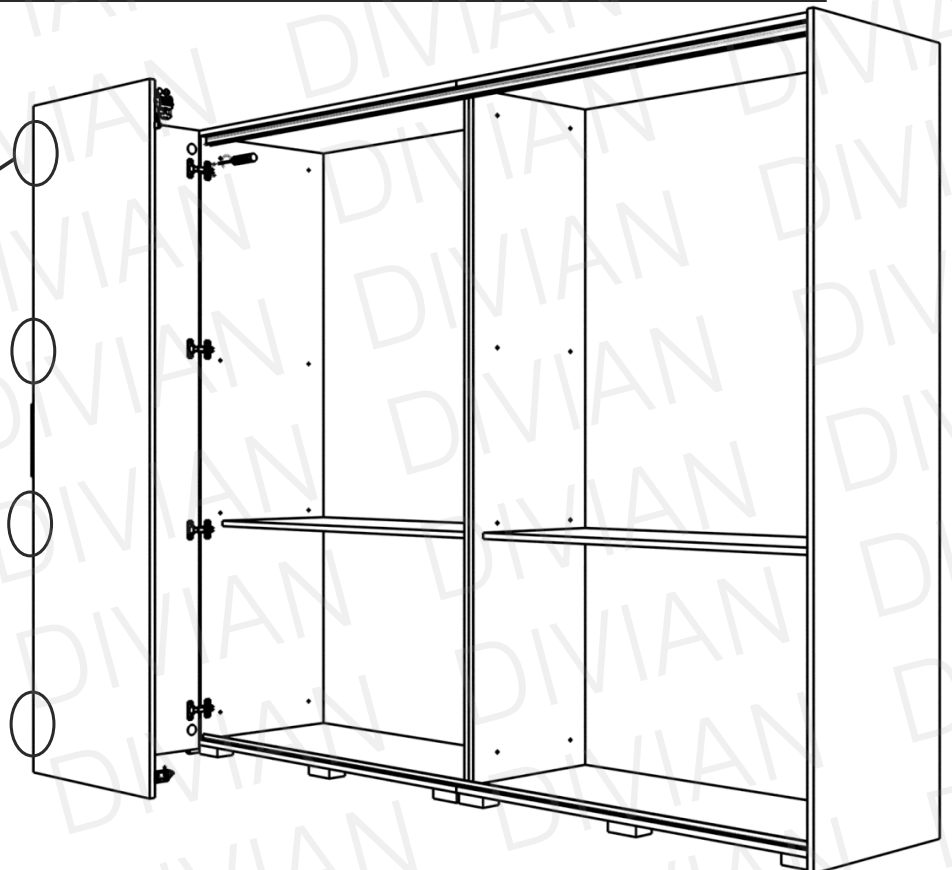
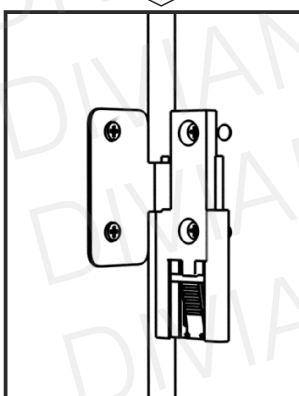
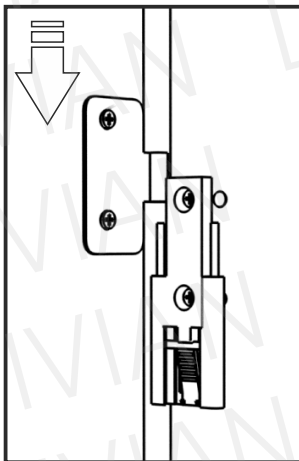

**11**

Hajtsák az ajtót a korpusz felé, a felső görgőt helyezték a felső sínre, majd tolják fel a belső görgőket is. Ezzel rázár a felső görgő a sínre.

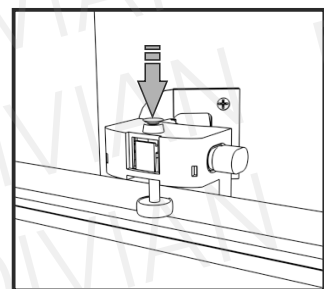
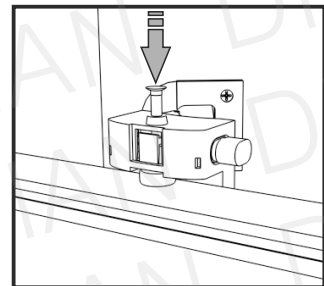
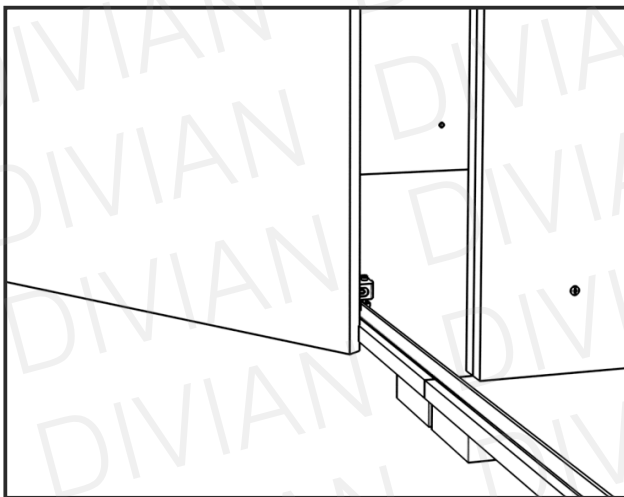
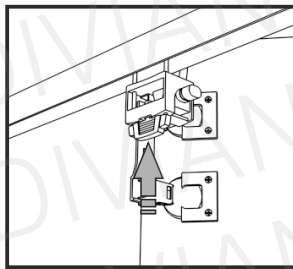
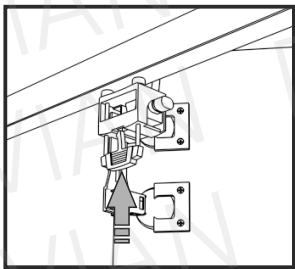
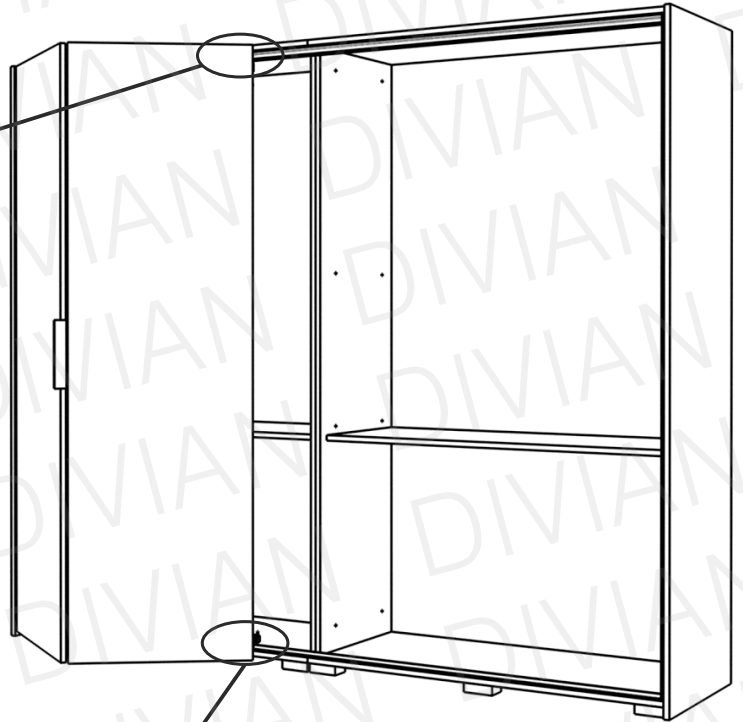
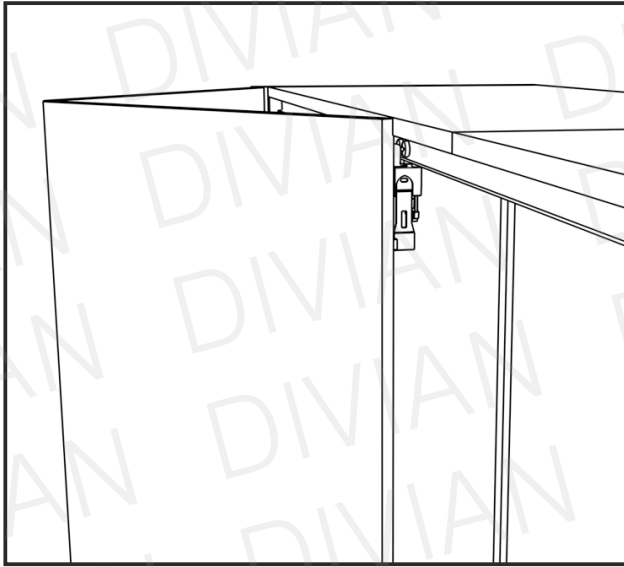

Az alsó görgőt helyezték az alsó sínre, majd nyomják le a kis fém rúd segítségével a belső görgőt. Ezzel rázár az alsó görgő a sínre.



Ismételjék meg a jobbos ajtó panelekkel is a 10. és 11. lépést!

**12**

Ha szükségesnek látják az ajtók magasságát állíthatják a felső görgő alsó csavarjával.

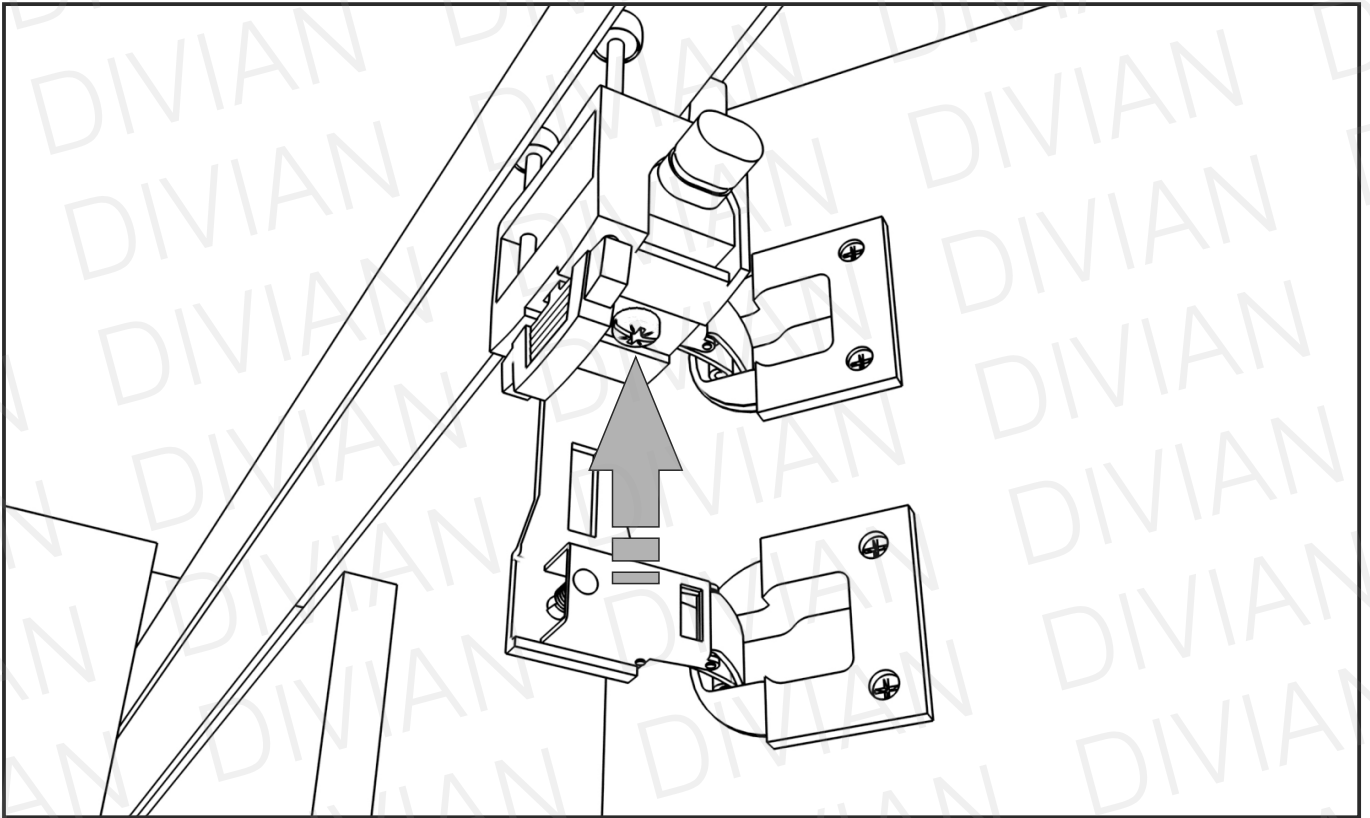
**13**

4x



8x

